

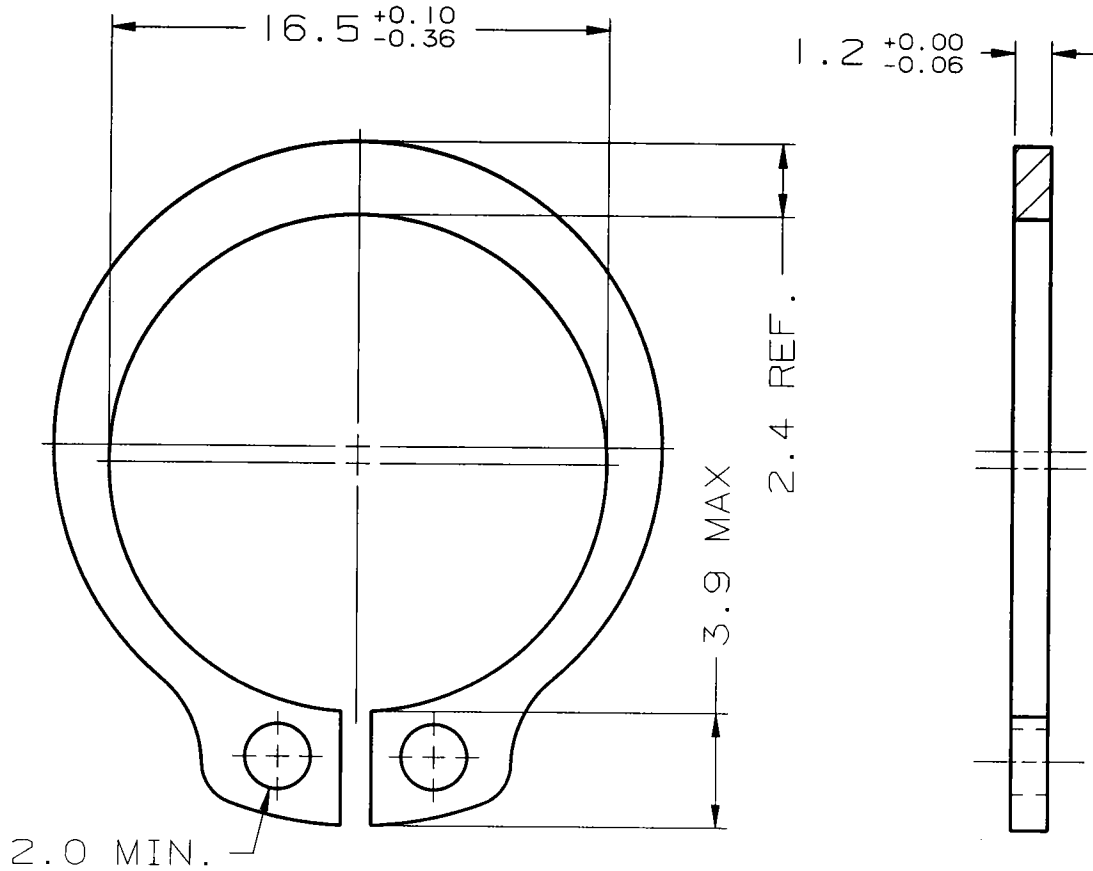

NOTE: ALL DIMENSIONS IN MILLIMETERS



SPECIFICATION : DIN 471-18  
 SHAFT DIA.: 18 mm (.709 in)  
 GROOVE DIA.: 17.0 <sup>+0.00</sup>/<sub>-0.11</sub> mm (.669 <sup>+0.000</sup>/<sub>-.004</sub> in)  
 GROOVE WIDTH : 1.3 mm MIN (.051 in)  
 HARDNESS : Rc 47-54  
 MATERIAL : SPRING STEEL

1 2/25 GWF

ECN 97-082

REV. NO.	DATE	REV. BY	ECN NUMBER		ROTOR CLIP CO., INC. 		
REVISION				DSH-18 CUSTOMER DRAWING			
WARNING: IF PRINTED, IT IS THE USERS RESPONSIBILITY TO CHECK THAT THIS DOCUMENT REFLECTS THE LATEST REVISION LEVEL.					SCALE <b>NONE</b>		
					DRAWN BY <b>RWG</b>		
					DATE <b>7/31/90</b>		
					FILE NAME: <b>(DSH182)</b>		
MATERIAL	HEAT TREAT	FINISH	QTY. REQ'D.		DWG. NO. <b>DSH-18-2</b>		
THE CONTENTS OF THIS DRAWING IS THE PROPERTY OF ROTOR CLIP CO. INC. AND SHALL BE RETURNED TO ROTOR CLIP CO. INC. UPON REQUEST. ANY UNAUTHORIZED DISCLOSURE OF ITS CONTENTS WITHOUT THE PERMISSION OF ROTOR CLIP CO. INC. IS PROHIBITED.					DWG. SIZE <b>A</b>		